

SETTING UP PROCEDURE

1. Remove the two screws holding the cover plate in position and move it towards the back of the player. The mains tapping panel will then be exposed to view.
2. Set the mains voltage adjustment pin to the correct position.
3. Check that the valve is firmly pressed into its socket.
4. Replace cover plate and screws.

CIRCUIT DESCRIPTION

The ECL82 is a triode-pentode valve. The triode section is used in a voltage amplifying circuit and is resistance-capacity coupled to the pentode which is used in the power output circuit. Bias for the pentode is obtained from the by-passed resistor R8 (470Ω) in its cathode circuit. Grid current bias is obtained from the triode by means of R3 (10 MΩ) and the blocking condenser C3 (·01 μF.) in its grid circuit.

Negative voltage feedback of middle and high frequencies is obtained from the secondary of the output transformer and is fed via R11 (4·7 KΩ) and C9 (0·1 μF.) into the bottom of the volume controls so that the amount of negative feedback is increased as volume is reduced.

The feedback is also used to boost the bass response as bass frequencies are not fed back.

The mains transformer is of the completely isolated type and supplies the full-wave metal rectifier and reservoir capacitor C8 (30 μF.). A tapped output transformer is used giving hum bucking in conjunction with R6 (680Ω) and C1 (10 μF.), a further stage of smoothing follows R5 (8·2 KΩ) and C2 (20 μF.).

Tone control is by means of an inverse log law potentiometer (500 KΩ) and condenser C7 (·003 μF.) in the grid circuit of the pentode.

The negative rail of the amplifier is connected to the loudspeaker chassis and also to a metal foil on the cabinet bottom, to reduce hum.

Two resistors R12 (220 KΩ) and R13 (470 KΩ) are mounted on a small tag strip on the changer and also screened.

REMOVAL OF PRINTED CIRCUIT ASSEMBLY FROM CABINET

1. Remove the two screws holding the cover plate in position.
2. Remove the five screws holding the motor board in position.
3. Remove the control knobs (grub screws).
4. The cover plate can then be disengaged from the motor board and the record changer and motor board lifted out and placed on the left-hand side of the cabinet.
5. Remove the cleat securing the mains lead to the cabinet. Unsolder the wire from the loudspeaker chassis to the metal foil on the bottom of the cabinet.
6. Remove the two 4BA nuts holding the front panel to the cabinet.
7. The front panel and plastic grill assembly can then be eased backwards and separated.
8. The printed board can then be detached from the front panel by undoing the two 4BA nuts. This leaves the amplifier connected to the loudspeaker and record changer.
9. The pickup lead can then be unsoldered at the volume control, the mains supply to the record changer at the On/Off switch, and the leads can be disconnected from the speaker leaving the printed board completely free.

COIL AND TRANSFORMER DATA

Circuit Ref. No.	Function	Approximate Resistance in ohms
L.3, 4, 5	Mains Transformer	
	Primary	190Ω
	Secondary H.T.	298Ω
L.1, 2	Secondary L.T.	Less than 1Ω
	Output Transformer	
	Primary Start to tap	700Ω
	Tap to finish	20Ω
	Secondary	0·5Ω

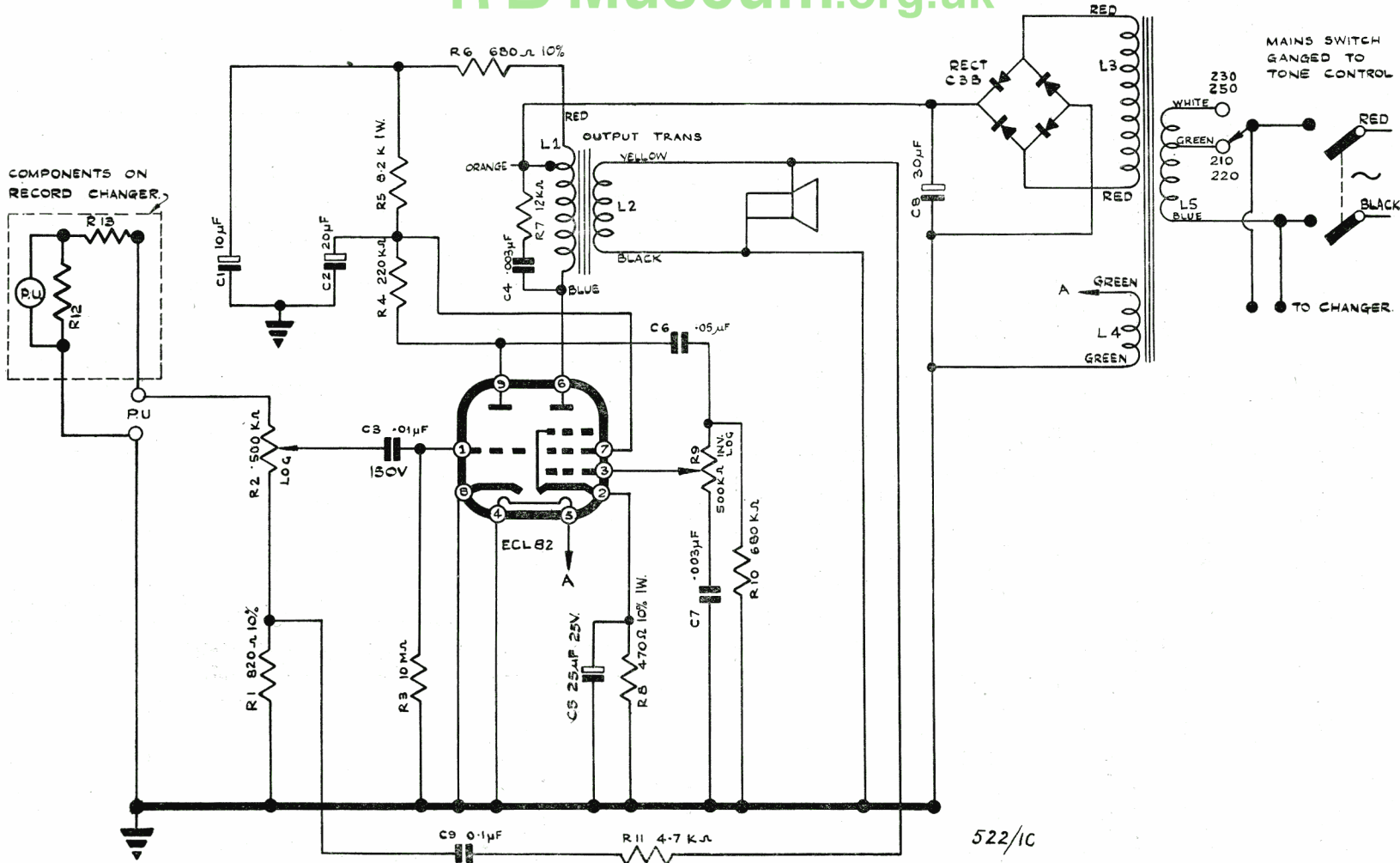

R12 VALUE 220KΩ FOR "B.S.R." CHANGER
 R12 VALUE 470KΩ FOR "COLLARO" CHANGER.
 R13 VALUE 470KΩ FOR "B.S.R." CHANGER
 R13 NOT USED ON "COLLARO" CHANGER.

ALL RESISTORS ± 20% 1/2 WATT UNLESS OTHERWISE STATED
 ALL CONDENSERS ± 20% 350V UNLESS OTHERWISE STATED.

522/1C

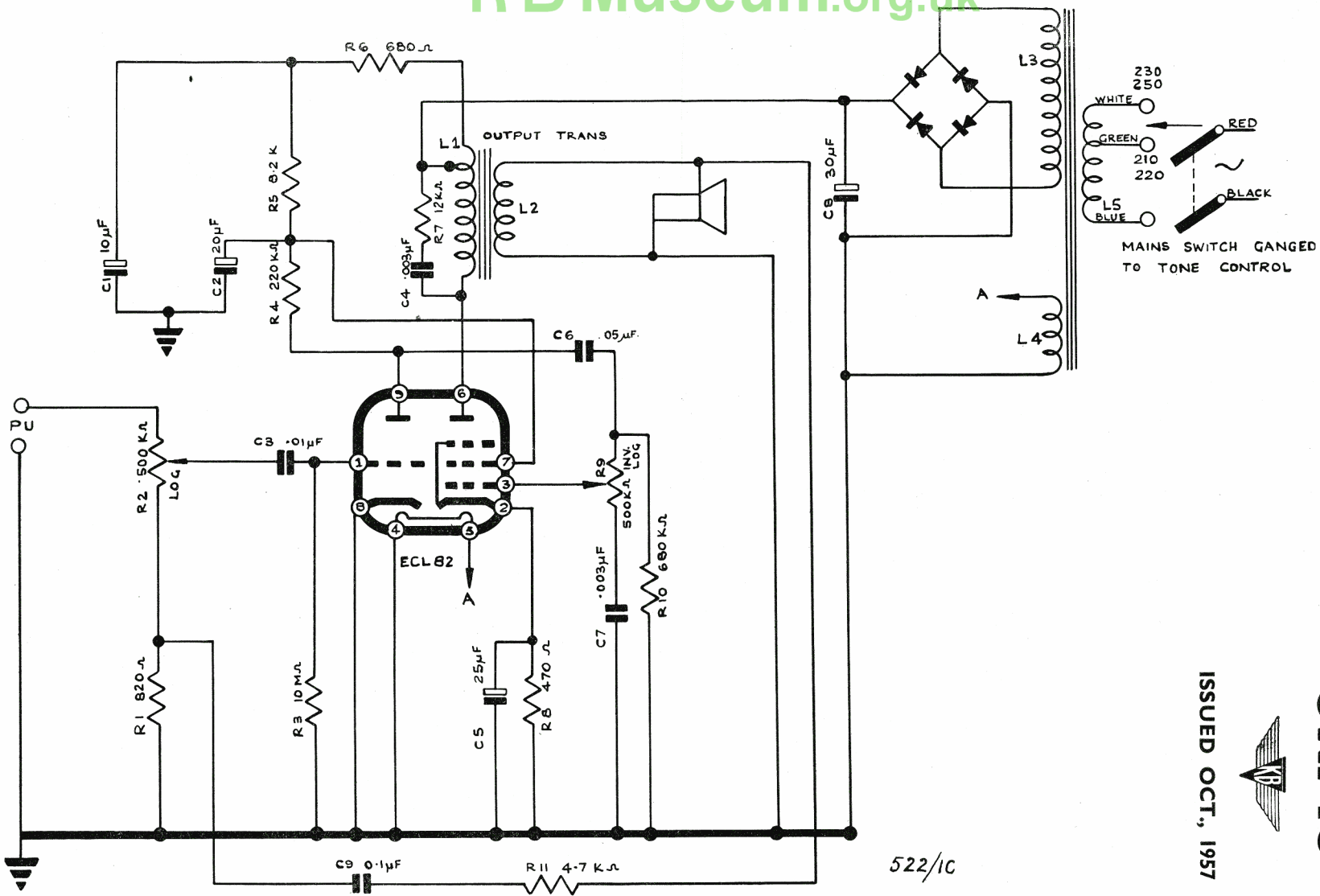

522/1c

ISSUED OCT., 1957



MODEL
ORPIO

PRINTED CIRCUIT

K&B Museum.org.uk

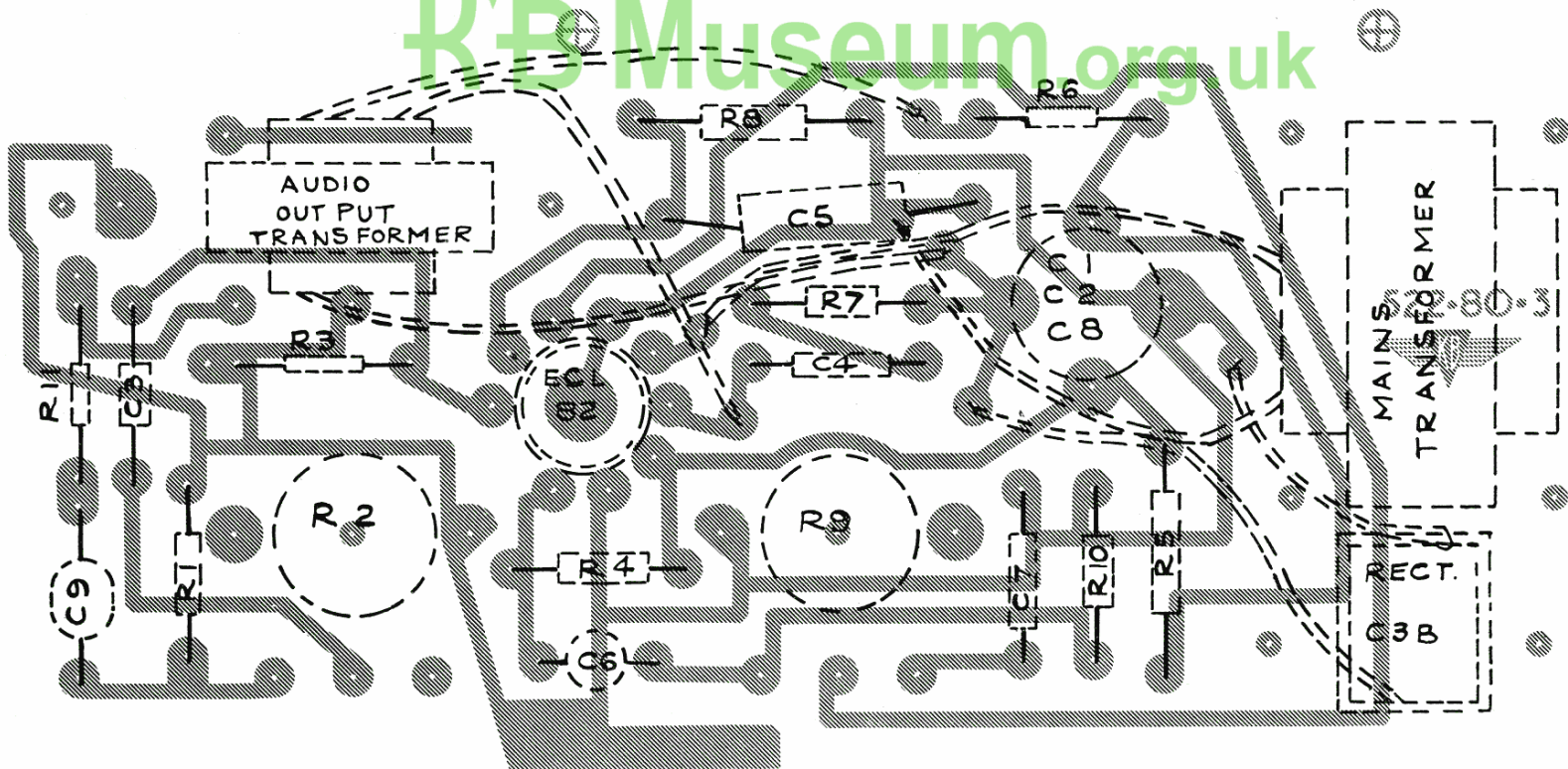

KB Museum.org.uk

UNDER VIEW OF CHASSIS

